

KAD/ADC/129/S2

Full-bridge ADC (voltage excitation, programmable analog gain, sense lines, 25kHz b/w) - 4ch at 100ksps



Key Features

- Four full or 1/2-bridge, potentiometer or differential ended input channels
- Programmable input range ($\pm 10\text{mV}$ to $\pm 10\text{V}$)
- High accuracy (0.02% FSR typical for range of 1V and 10V)
- Programmable voltage excitation with separate sense lines and balance adjust
- Short on any channel does not affect others
- 16-bit simultaneous sampling on each channel

Applications

- Bridge sensors and strain gage measurement
- Differential voltage measurement

Overview

The KAD/ADC/129/S2 has four channels of signal conditioning and data acquisition for differential voltages, strain gage or bridge measurements. In addition to the measurement channel, the KAD/ADC/129/S2 provides independent bipolar excitation for up to four channels. Each differential ended signal has a separate programmable amplifier, filter and A/D converter.

At the heart of the KAD/ADC/129/S2 is a hard-wired state-machine that over-samples all channels at a rate between 200ksps and 400ksps and digitally filters any noise above the user-programmable cutoff frequency. This is achieved using cascaded, half-band, decimate by 2 x 15-tap, Finite-Impulse-Response (FIR) filters followed by an 8th order Butterworth Infinite-Impulse-Response (IIR) filter with a default cutoff point set at a quarter of the sampling frequency. All signals are sampled simultaneously. Thus, when several channels are sampled at different sampling rates, all channels will be aligned at the start of an acquisition cycle.

The KAD/ADC/129/S2 is intended for use with strain gages, and should not be used for asymmetric bridge transducers such as accelerometers, pressure transducers unless sensor re-calibration is carried out on a channel-by-channel basis. If the sense lines or internal offset adjust (balance feature) are not required, refer to the KAD/ADC/129/S1.

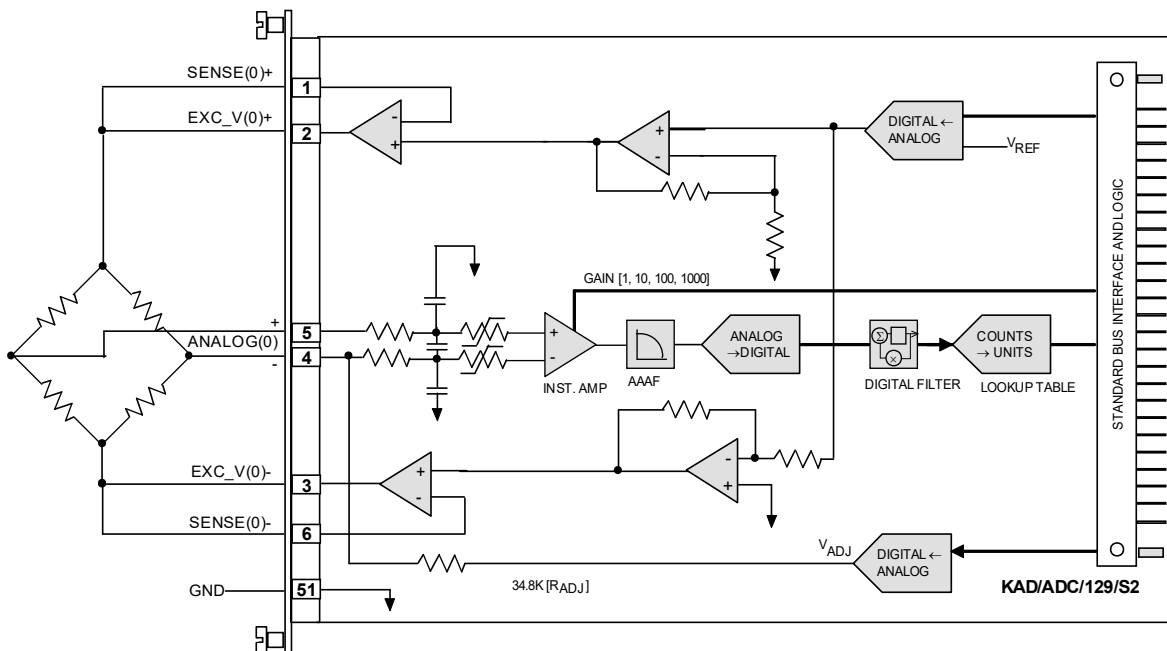

Figure 1: First of four channels on the KAD/ADC/129/S2

Specifications

All values provided in the following specification tables are valid within the operating temperature range specified under “Environmental ratings” in the “General specifications” table. Module specifications are met for up to 97% of Full Scale Range (FSR).

TABLE 1		General specifications				
PARAMETER	MIN.	TYP.	MAX.	UNITS	CONDITION/DETAILS	
Slots	–	–	1	–	Can be placed in any user-slot in any combination.	
Mass						
	–	90	–	g		
	–	3.17	–	oz	Design metric is grams.	
Height above chassis					For recommended clearance requirements see the <i>CON/KAD/002/CP</i> data sheet.	
bare connector	–	–	11	mm		
bare connector	–	–	0.43	in.	Design metric is millimeters.	
Access rate	–	–	2	Msp/s	Maximum combined access rate for read and write.	
Power consumption						
+5V	100	–	180	mA		
+7V	15	–	30	mA	Excludes current used by excitation.	
-7V	10	–	25	mA	Excludes current used by excitation.	
+12V	50	–	80	mA		
-12V	40	–	70	mA		
total power	1.75	–	3.09	W	Particular combinations of chassis and Acra KAM-500 modules may have power or current limitations. For details, see <i>TEC/NOT/016 - Power dissipation</i> , <i>TEC/NOT/049 - Power estimation</i> , and the relevant chassis data sheet.	
Environmental ratings					See <i>Environmental Qualification Handbook</i> .	
operating temperature	-40	–	85	°C	Chassis base/side plate temperature.	
storage temperature	-55	–	105	°C		

TABLE 2		Differential ended analog inputs				
PARAMETER	MIN.	TYP.	MAX.	UNITS	CONDITION/DETAILS	
Inputs	–	–	4	–		
Sampling rate					While the sampling rate can be set individually, each must have a power of two times any other (1/4, 1/2 ...2, 4).	
ANALOG[3:0]	2	–	100,000	sps		
Input voltage						
operating range ($G_p = 1$)	-10	–	10	V	Primary gain = 1.	
operating range ($G_p = 10$)	-1	–	1	V	Primary gain = 10.	
operating range ($G_p = 100$)	-100	–	100	mV	Primary gain = 100.	
operating range ($G_p = 1000$)	-10	–	10	mV	Primary gain = 1000.	
overvoltage protection	-40	–	40	V	Voltages outside of this range can damage input.	

TABLE 2 Differential ended analog inputs (continued)

PARAMETER	MIN.	TYP.	MAX.	UNITS	CONDITION/DETAILS
DC error					DC signal averaged over 200 samples without excitation.
gain = 1, 10	–	0.02	0.08	%FSR	
gain = 2, 20	–	–	0.14	%FSR	
gain = 4, 40	–	–	0.25	%FSR	
gain = 8, 80	–	–	0.44	%FSR	
gain = 100	–	0.04	0.18	%FSR	
gain = 200	–	–	0.33	%FSR	
gain = 400	–	–	0.6	%FSR	
gain = 800	–	–	1.2	%FSR	
gain = 1000	–	0.3	1.5	%FSR	
AC gain error					Note that the figures presented here include analog anti-aliasing filter and digital filter amplitude errors. For gain ≥ 1000 , an additional error exists, which is caused by a much lower bandwidth of instrumentation amplifier for that gain, which is typically 60kHz (-3dB point), and has the shape of a 1st order filter.
	–	0.02	0.1	%FSR	For $f_{in} \leq 3\text{kHz}$, $f_s = 100\text{kHz}$, $f_c = f_s / 4$ (f_{in} : input signal frequency; f_s : sampling frequency; f_c : filter cutoff frequency).
	–	0.1	0.35	%FSR	For $3\text{kHz} < f_{in} \leq 10\text{kHz}$, $f_s = 100\text{kHz}$, $f_c = f_s / 4$.
	–	0.35	0.8	%FSR	For $10\text{kHz} < f_{in} \leq 15\text{kHz}$, $f_s = 100\text{kHz}$, $f_c = f_s / 4$.
Effective number of bits					
gain = 1, 10	12	13.5	–	bits	$f_c \leq 25\text{kHz}$ and secondary gain of 1 (f_c : filter cutoff frequency).
gain = 100	11.5	12.5	–	bits	$f_c \leq 25\text{kHz}$ and secondary gain of 1.
gain = 1000	9	10.5	–	bits	$f_c \leq 25\text{kHz}$ and secondary gain of 1.
Crosstalk					
gain = 1, 10, 100	–	-100	-90	dB	$f_{in} \leq 25\text{kHz}$ and secondary gain of 1.
gain = 1000	–	-80	-72	dB	$f_{in} \leq 25\text{kHz}$ and secondary gain of 1.
Common mode					
voltage range	-10	–	10	V	Operational voltage range.
rejection ratio	72	80	–	dB	Applies within the above common mode voltage range, $0 \leq f \leq f_c$.
Analog filter					Analog filter is Butterworth.
poles	–	–	6	–	
filter cutoff -3dB	38	40	42	kHz	
Digital filter					Digital filter is Butterworth.
poles	–	–	8	–	
filter cutoff -3dB	0.25	–	16	f_s	The maximum value is limited to 25kHz (f_s : sampling frequency).
0.1dB bandwidth	–	0.8	–	f_c	
aliasing to 0.1dB band	–	–	-80	dB	
aliasing to f_c	–	–	-80	dB	

TABLE 2 Differential ended analog inputs (continued)

PARAMETER	MIN.	TYP.	MAX.	UNITS	CONDITION/DETAILS
Filter delay	–	200	–	μs	Where $f_{in} = f_c = 10\text{kHz}$ (f_{in} : input signal frequency).
Input resistance					
between inputs	10	–	–	MΩ	Whether module powered on or off.
single ended input to GND	–	34.8	–	kΩ	Module powered on Measured on ANALOG(x)- input.
single ended input to GND	43	52	–	kΩ	Module powered off. Measured on ANALOG(x)- input.
single ended input to GND	10	–	–	MΩ	Whether module powered on or off. Measured on ANALOG(x)+ input.
Input impedance					
between inputs	–	300	–	kΩ	Module powered on (measured at 3kHz).
single ended input to GND	–	300	–	kΩ	Module powered on (measured at 3kHz).

TABLE 3 Bipolar DC voltage excitation outputs

PARAMETER	MIN.	TYP.	MAX.	UNITS	CONDITION/DETAILS
Outputs	–	–	4	–	Applied per channel.
Output voltage					
operating range	0	–	5.1	V	Bi-polar excitation: 5V is 10V across the bridge.
resolution	–	1.8	–	mV	Bi-polar excitation: 1.8mV is 3.6mV across the bridge.
compliance	–	–	30	mA	Per channel.
short circuit current	–	–	125	mA	
short circuit duration	∞	–	–	s	
DC error					
error	–	0.1	0.3	%FSR	With a constant 350Ω load.
noise (gain = 1)	–	–	0.5	mV _{rms}	As measured on analog input.
noise (gain = 10)	–	–	0.05	mV _{rms}	As measured on analog input.
noise (gain = 100, 1000)	–	–	0.01	mV _{rms}	As measured on analog input.
Output resistance	–	0.2	–	Ω	

TABLE 4

Balance current outputs¹

PARAMETER	MIN.	TYP.	MAX.	UNITS	CONDITION/DETAILS
Outputs	-	-	4	-	Applied per channel. Connected internally with corresponding ANALOG(x)- input.
Output current					
operating range	-71	-	71	μA	
resolution	-	35	-	nA	
DC error					
error	-	-	2	%FSR	With a constant 175Ω load. The impact of this error on the channel reading is less than 0.01%FSR (200 times lower than the error specified here).
drift	-	-	0.15	%FSR	Over temperature.
noise (gain = 1)	-	-	0.5	mV _{rms}	As measured on analog input.
noise (gain = 10)	-	-	0.05	mV _{rms}	As measured on analog input.
noise (gain = 100, 1000)	-	-	0.01	mV _{rms}	As measured on analog input.
Output resistance	-	34.8	-	kΩ	

1. The balance line is permanently connected to ANALOG(x)- input. The line is intended for balancing strain gages, so the module should not be used for asymmetric bridge transducers such as accelerometers or pressure transducers unless sensor re-calibration is carried out on a channel-by-channel basis.

Setting up the KAD/ADC/129/S2

All module setup can be defined in XML using XidML® schemas (see <http://www.xidml.org>).

Instrument settings

SETUP DATA	CHOICE	DEFAULT	NOTES
Manufacturer	-	-	-
Name	ACRA CONTROL	ACRA CONTROL	Name of manufacturer.
PartReference	KAD/ADC/129/S2	KAD/ADC/129/S2	The instrument part reference.
SerialNumber	AB1234	AB1234	Unique name for each module.
Channels	-	-	-
AnalogIn(3:0)	-	-	-
Analog Input	-	-	-
Settings	-	-	-
Filter Cutoff	0.25 0.5 1 2 4 8 16	0.25	Required cutoff point for the filter is the chosen value multiplied by the user sampling frequency. 0.25 is recommended as any higher may lead to aliasing. 1 is the sampling rate.
Excitation Amplitude	0 to 5.1	0.2	Required excitation (in V) for the top of the bridge. Excitation is bipolar so entering 5V means 10V across the bridge.
Balance.Type	CurrentShunt	CurrentShunt	Specifies the balance type to be carried out on the bridge.
Balance.Applied	-71e-6 to 71e-6	0	Shunt current (in A) applied to the bridge.
Balance.BalanceThisTime	True False	False	Specifies if balancing should be carried out this time by software.
Balance.Tolerance	0.01 to 99.99	0.1	Specifies acceptable tolerance of achieved value vs. target value, expressed as percentage of defined input range.
Balance.Target	-10 to 10	0	Specifies a value. that the channel should be balanced to.
ShuntCurrent.Applied	-71e-6 to 71e-6	0	Shunt mode current (in A) added to the bridge

Parameter definitions

NAME/DESCRIPTION	BASE UNIT	DATA FORMAT	BITS	REGISTER DEFINITION
AnalogIn(3:0) Parameters				
AnalogIn Analog signal data	Volt	OffsetBinary	16	R[15:0]

Configurable parameters

AnalogIn(3:0)

SETUP DATA	CHOICE	DEFAULT	NOTES
Range Maximum	-10 to 10	10	Range maximum for analog channel
Range Minimum	-10 to 10	-10	Range minimum for analog channel

NOTE: It is recommended that names are less than 20 characters, have no white space or contain any of the following five characters "><\"/>

Getting the most from the KAD/ADC/129/S2

Wiring configurations

Figures 2 to 4 show possible wiring configurations for the KAD/ADC/129/S2.

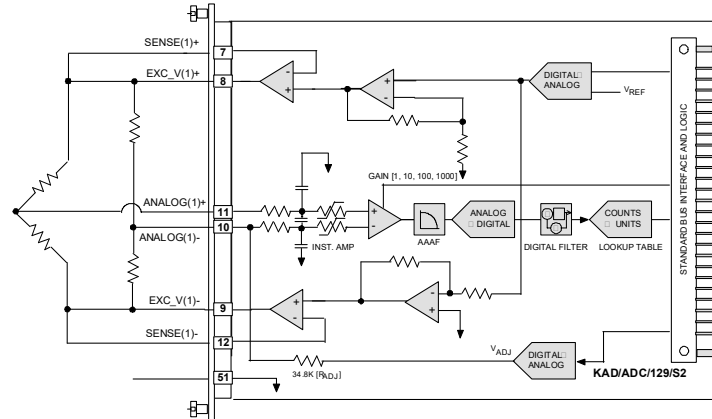

Figure 2: Second of 4 independent 1/2-bridge channels with matched pair completion resistors

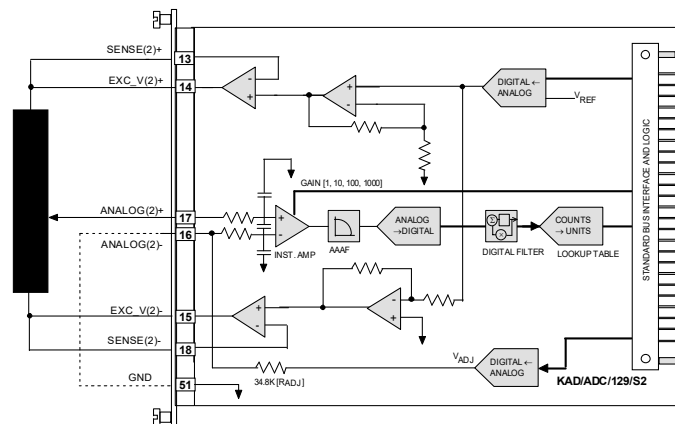

Figure 3: Third of 4 independent potentiometer channels

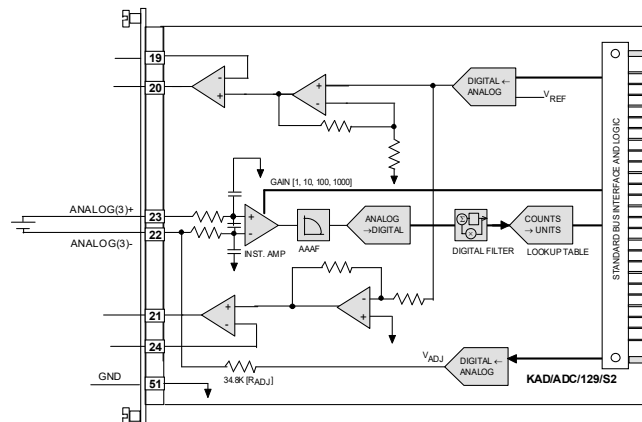

Figure 4: Fourth of 4 independent differential ended channels

Bias current return path

As shown in Figure 4 on page 7, the analog inputs can be used as differential inputs (that is, not from a bridge). In this case, if the signal source is isolated with respect to the Acra KAM-500 (for example a battery), a common-mode resistance between the negative input and ground (GND) should be used to provide a return for bias currents and reduce common-mode noise pick-up. Because the bias currents are in the order of nAs resistors up to 10k Ω can be used. In most cases a short (0 Ω) is recommended.

NOTE: When analog inputs are used as differential inputs, setting the excitation and balance to zero reduces quiescent currents of the module.

Using high primary gains

For gains above 1000, the gain-bandwidth product of the amplifier reduces the bandwidth of the instrumentation amplifier to approximately 60kHz. The effect of attenuation can be seen for input signals with frequencies of 10kHz and higher.

Excitation setup

Excitation can contribute error to the overall measurement, so it is recommended to use as close as possible to full-scale excitation, to minimize the percentage error.

For optimal accuracy ensure each channel uses its corresponding excitation. If the excitation is not used, it should be set to the minimum value.

Excitation drift on potentiometer configurations

Curtiss-Wright recommends a full-bridge input configuration for the KAD/ADC/129/S2. With this configuration the differential input amplifier removes common mode voltage or common mode pickup noise on the input lines.

For potentiometer circuits where the negative input is tied to ground, excitation drift can have a direct impact on the input signal either as a gain or an offset error. Note that excitation can drift up to 0.3% on an FSR of 5.1V. In the case where both excitation lines drift in the same direction an offset error is seen in the measurement. The worst case possible offset is 0.3% of 5.1V and results in a worst case 15.3mV offset of the measurement. This does not happen with full-bridge configurations. We recommend that the negative input is tied to ground as shown in Figure 3 on page 7. If the negative input is floating, the drift of the digital/analog converter related to the balancing input directly adds further offset error to the measurement.

Source load error caused by the balance adjust circuit

The balance circuit has an impedance of R_{ADJ} and is connected to the ANALOG(x)- input of the module. This connection is performed internally on the module. In some bridge configurations, R_{ADJ} loads the source signal causing a quantifiable error. An example schematic for a full-bridge configuration loaded with balance resistance is shown in the following figure.

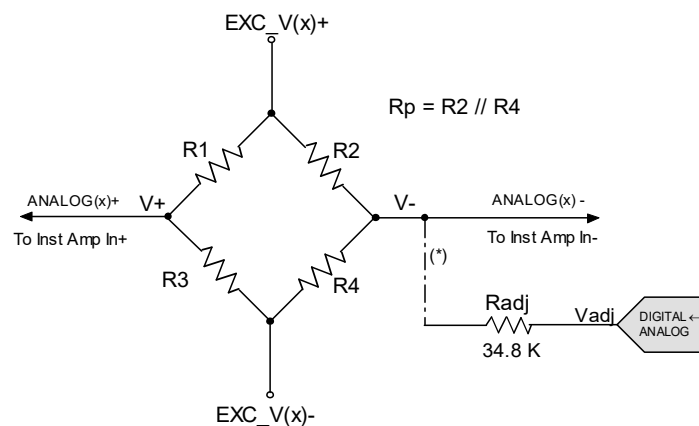

(*) Connection between V- and Radj is internal or external depending on module

Figure 5: Full-bridge configuration loaded with balance resistance

The DC error specification is checked as a differential input, so it does not include loading by R_{ADJ} which causes an additional gain error.

In the previous figure, the gain error only occurs when the active leg of the bridge is connected to ANALOG(x)-. In this situation, ANALOG(x)- is loaded by R_{ADJ} , forming a resistor divider with the resistance of bridge visible from the ANALOG(x)- input.

The gain error on ANALOG(x)- input can be quantified as follows:

$$Error = -\left(\frac{R_P}{R_P + R_{adj}}\right) \times 100\%$$

where $R_P = R_2$ in parallel with R_4

This additional gain error depends on the resistance of the bridge and can be typically -0.5% for a 350 Ω bridge with its active leg connected to ANALOG(x)-, and -0.172% for a 120 Ω bridge.

In the case of a full-bridge with two active legs, only one leg of the bridge is affected. Therefore the gain error of voltage across the bridge is half of the above quoted figures, that is, -0.25% for a 350 Ω bridge.

For a symmetrical input range, the error can be expressed as %FSR error by further dividing the value by two, yielding to $\pm 0.125\%$ FSR for a 350 Ω bridge.

Note that the gain error due to R_{ADJ} does not apply when:

- using a wheatstone bridge with the active elements (typically strain gages) placed only on the leg of the bridge connected to ANALOG(x)+
- the leg of the bridge connected to ANALOG(x)- is populated with completion resistors (half-bridge with completion resistors)
- using only differential ended inputs with signal source isolated from module ground
- using only inputs in single ended configuration, connecting the signal to ANALOG(x)+ (ANALOG(x)- must be connected to ground). This data sheet shows an example potentiometer application, which is not affected by this gain error.

Modules with R_{ADJ} connected externally might show this additional gain error offset but only if the balance adjust circuit is used and in the cases stated previously.

NOTE: Gain error can be compensated at post processing, as the nominal resistance of the bridge is known.

Understanding filter delays

The Acra KAM-500 uniquely samples all signals at the start of an acquisition cycle and at equal intervals of time thereafter. Signals sampled at the same sample rate will always be sampled at the same time independently of how they are stored or transmitted. (This has significant advantages for issues such as time correlation.) However, before signals are sampled they are filtered to remove noise components that might alias. The recommended cutoff point is one quarter the sampling frequency, as this results in the maximum filtering of aliasing frequencies.

The Acra KAM-500 filters signals using over-sampling signal processing techniques. The figure below shows a delay for an 8th order filter where $f_c = 1\text{kHz}$. All filters cause a delay inversely proportional to the filter cutoff frequency (f_c), so to calculate the delay for other f_c values, multiply the delay by $(1\text{kHz} / f_c)$. The frequency axis then needs to be rescaled to the new f_c by dividing the frequency values by $(1\text{kHz} / f_c)$. For example, an 8th order Butterworth filter with an f_c of 1kHz delays a 1kHz signal by 1ms; a filter with an f_c of 10Hz delays a 10Hz signal by 0.1s. The delay for IIR filters (for example Butterworth) varies with the input frequency.

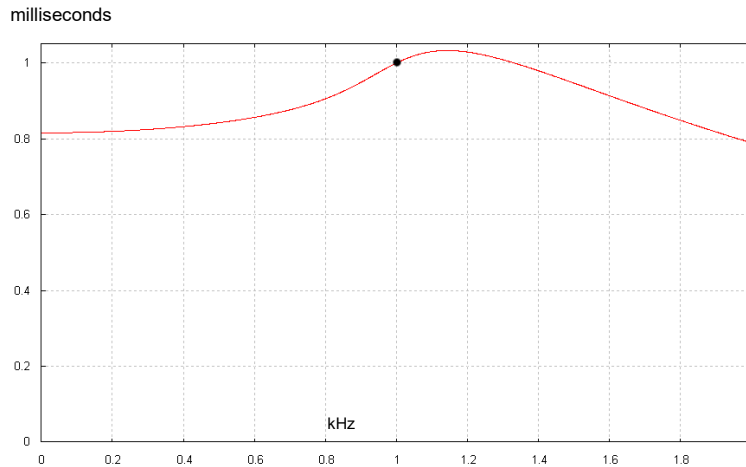

Figure 6: Filter delay for 8th order Butterworth filter where $f_c = 1\text{kHz}$

The filter delay for the KAD/ADC/129/S2 is:

$$T_D \approx T_A + \frac{1}{f_C} + T_{\text{Butterworth}8}(f)$$

T_D is the filter delay

T_A (analog filter delay) ≈ 0

Additional delay sources

Primary gains higher than 10 cause an additional delay from 1st order filters in the instrumentation amplifier. That additional delay is in the order of $0.25\mu\text{s}$, for a gain of 100, and $2.5\mu\text{s}$ for a gain of 1,000.

In applications where time correlation is more important than suppression of aliasing, set the same cutoff point on all channels, even if the sampling rates are different.

Sense lines

Sense lines are used to eliminate error due to voltage drop across lead resistance. Sense lines can not be left unconnected; they should be connected as close as possible to the bridge. If however, the sense lines are connected close to the module (that is, far from the bridge) and the lead resistance can be measured or estimated, add the voltage drop across the leads to the excitation voltage. For example, for 0.5Ω leads in a 350Ω full-bridge where $\pm 5\text{V}$ (10V) is desired across the bridge, the excitation must be set to $5\text{V} + (0.5 \times 10/350) = \pm 5.014$.

Connector pinout of the KAD/ADC/129/S2

PIN	NAME	SEE SPECIFICATIONS TABLE	COMMENT
1	SENSE(0)+	Bipolar DC voltage excitation outputs	Sense line from top of bridge
2	EXC_V(0)+	Bipolar DC voltage excitation outputs	Excitation to top of bridge
3	EXC_V(0)-	Bipolar DC voltage excitation outputs	Excitation to bottom of bridge
4	ANALOG(0)-	Differential ended analog inputs	Analog input connected to internal adjust
5	ANALOG(0)+	Differential ended analog inputs	Analog input
6	SENSE(0)-	Bipolar DC voltage excitation outputs	Sense line from bottom of bridge
7	SENSE(1)+	Bipolar DC voltage excitation outputs	Sense line from top of bridge
8	EXC_V(1)+	Bipolar DC voltage excitation outputs	Excitation to top of bridge
9	EXC_V(1)-	Bipolar DC voltage excitation outputs	Excitation to bottom of bridge
10	ANALOG(1)-	Differential ended analog inputs	Analog input connected to internal adjust
11	ANALOG(1)+	Differential ended analog inputs	Analog input
12	SENSE(1)-	Bipolar DC voltage excitation outputs	Sense line from bottom of bridge
13	SENSE(2)+	Bipolar DC voltage excitation outputs	Sense line from top of bridge
14	EXC_V(2)+	Bipolar DC voltage excitation outputs	Excitation to top of bridge
15	EXC_V(2)-	Bipolar DC voltage excitation outputs	Excitation to bottom of bridge
16	ANALOG(2)-	Differential ended analog inputs	Analog input connected to internal adjust
17	ANALOG(2)+	Differential ended analog inputs	Analog input
18	SENSE(2)-	Bipolar DC voltage excitation outputs	Sense line from bottom of bridge
19	SENSE(3)+	Bipolar DC voltage excitation outputs	Sense line from top of bridge
20	EXC_V(3)+	Bipolar DC voltage excitation outputs	Excitation to top of bridge
21	EXC_V(3)-	Bipolar DC voltage excitation outputs	Excitation to bottom of bridge
22	ANALOG(3)-	Differential ended analog inputs	Analog input connected to internal adjust
23	ANALOG(3)+	Differential ended analog inputs	Analog input
24	SENSE(3)-	Bipolar DC voltage excitation outputs	Sense line from bottom of bridge
25	DNC		Do not connect
26	DNC		Do not connect
27	DNC		Do not connect
28	DNC		Do not connect
29	DNC		Do not connect
30	DNC		Do not connect
31	DNC		Do not connect
32	DNC		Do not connect
33	DNC		Do not connect
34	DNC		Do not connect
35	DNC		Do not connect
36	DNC		Do not connect
37	DNC		Do not connect
38	DNC		Do not connect
39	DNC		Do not connect
40	DNC		Do not connect
41	DNC		Do not connect
42	DNC		Do not connect
43	DNC		Do not connect
44	DNC		Do not connect
45	DNC		Do not connect
46	DNC		Do not connect
47	DNC		Do not connect
48	DNC		Do not connect
49	DNC		Do not connect
50	DNC		Do not connect
51	GND	Internal ground	
52	CHASSIS	Chassis	

Ordering information

PART NUMBER	DESCRIPTION
KAD/ADC/129/S2	Full-bridge ADC (voltage excitation, programmable analog gain, sense lines, 25kHz b/w) - 4ch at 100ksps

By default, the standard mating connector, CON/KAD/002/CP, is included with each module in the shipment. Its part number will be added to the Confirmation of Order unless an alternative option is specified (see the *Cables* data sheet).

The KAD/ADC/129/S2 uses power from the $\pm 7V$ power line for excitation and therefore cannot be used with KAM/CHS/04L, KAM/CHS/05F, KAM/CHS/03F, or KAM/CHS/02F.

Revision history

REVISION	DIFFERENCES	STATUS
KAD/ADC/129/S2	First release	Recommended for new programs

Supporting software

SOFTWARE	DETAILS
KSM-500	This module is supported by the KSM-500 suite of software tools

Related documentation

DOCUMENT	DETAILS
DOC/DBK/001	Acra KAM-500 Databook
DOC/GBK/002	Environmental Qualification Handbook
DOC/MAN/018	KSM-500 Databook
DOC/MAN/030	DAS Studio 3 User Manual
TEC/NOT/001	Strain gages and ideal bridges
TEC/NOT/016	Power dissipation
TEC/NOT/049	Power estimation