

KAD/MBM/102

MIL-STD-1553 bus monitor parser/packetizer - 4ch dual redundant

**CURTISS-
WRIGHT**

CURTISSWRIGHTDS.COM

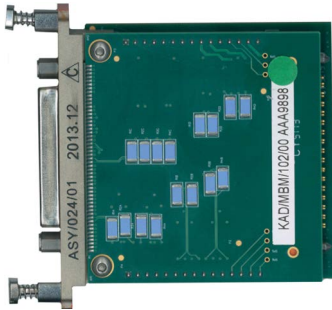

Key Features

- Monitors up to four dual redundant MIL-STD-1553 busses using Direct or Transformer coupled operation
- Coherently parses traffic and tags for up to 4,092 parser ID; parser ID based on 16-bit commands; RT-RT messages treated as one parser ID
- Aperiodic transmission of packetized MIL-STD-1553 messages including tags as iNET-X payload structure per channel
- Optional recording of messages with time-out status reply

Applications

- MIL-STD-1553 traffic monitoring and recording

Overview

The KAD/MBM/102 is a MIL-STD-1553 bus monitor, which can monitor up to four dual redundant busses. It combines the capabilities of a coherent message parser, with the flexibility of an iNET-X packetizer. It also provides message counting and extensive error detection functions, on a single module.

The KAD/MBM/102's parser, triple buffers up to 4,092 complete messages and their associated tags in buffers up to 43 words wide. The INFO tag associated with each message has a stale bit (message read before), a skipped bit (buffer overwritten) and an empty bit (no message received since power-on). These tags can be included as discrete parameters in Ethernet or PCM transmissions.

All messages are transparently added to an iNET-X parser-aligned packet and are sent aperiodically. This is achieved by oversampling the packet buffers with the Acra KAM-500 controller and silently dropping packets, which have already been sent saving bandwidth and media storage. iNET-X messages are optimized for Ethernet transmission and simultaneous storage in Wireshark® Packet CAPture (PCAP) format.

All messages are protocol tracked by the KAD/MBM/102. It handles all mode codes (including those that are user-defined).

The MessageCount increments on receipt of a valid message. The error word has bits (in the form of a 6-bit code) which indicate the type of error caught and the bus on which it occurred. Errors are also time stamped and recorded in the iNET-X packet.

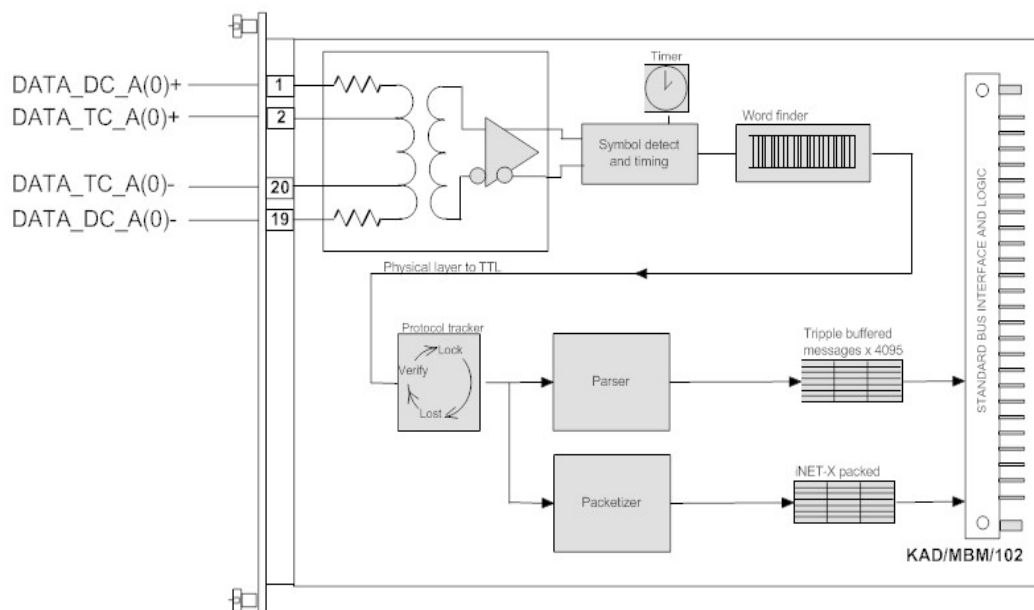

Figure 1: First of four bus parser/packetizers on the KAD/MBM/102

Specifications

All values provided in the following specification tables are valid within the operating temperature range specified under “Environmental ratings” in the “General specifications” table.

TABLE 1		General specifications				
PARAMETER	MIN.	TYP.	MAX.	UNITS	CONDITION/DETAILS	
Slots	–	–	1	–	Can be placed in any user-slot in any combination.	
Mass						
	–	90	–	g		
	–	3.17	–	oz	Design metric is grams.	
Height above chassis					For recommended clearance requirements see the <i>CON/KAD/002/CP</i> data sheet.	
bare connector	–	–	11	mm		
bare connector	–	–	0.43	in.	Design metric is millimeters.	
Access rate	–	–	2	Msp/s	Maximum combined access rate for read and write.	
Power consumption						
+5V	200	–	220	mA		
±7V	0	–	0	mA		
±12V	0	–	0	mA		
total power	1	–	1.1	W	Particular combinations of chassis and Acra KAM-500 modules may have power or current limitations. For details, see <i>TEC/NOT/016 - Power dissipation</i> , <i>TEC/NOT/049 - Power estimation</i> , and the relevant chassis data sheet.	
Environmental ratings					See <i>Environmental Qualification Handbook</i> .	
operating temperature	-40	–	85	°C	Chassis base/side plate temperature.	
storage temperature	-55	–	105	°C		

TABLE 2		MIL-STD-1553				
PARAMETER	MIN.	TYP.	MAX.	UNITS	CONDITION/DETAILS	
Inputs	–	–	4	–	Dual redundant. MIL-STD-1553-B compatible.	
Sampling rate	–	–	2	Msp/s	Maximum data rate of MIL-STD-1553 is 36kwps (72ksp/s).	
Input voltage						
operating range	1.36	–	20	V _{p-p}	Direct coupled.	
operating range	1.01	–	20	V _{p-p}	Transformer coupled.	
Connection methods						
transformer coupled	–	–	–	–		
direct coupled	–	–	–	–		

Setting up the KAD/MBM/102

All module setup can be defined in XML using XidML® schemas (see <http://www.xidml.org>).

Instrument settings

SETUP DATA	CHOICE	DEFAULT	NOTES
Manufacturer	-	-	-
Name	ACRA CONTROL	ACRA CONTROL	Name of manufacturer.
PartReference	KAD/MBM/102	KAD/MBM/102	The instrument part reference.
SerialNumber	AAA/1234	AAA/1234	Unique name for each module.
Settings	-	-	-
Fill Value	0000 to FFFF	AAAA	Specifies the value that should be stored when the bus monitor is not receiving data.
Packetization	Dual Redundant Individual	Individual	Selects packetization on a pair of busses or an individual bus.
Processes	-	-	-
Catchall-Parser	-	-	Any message that is not parsed goes to this final parser slot.
Channels	-	-	-
MIL-STD-1553-In-A(3:0)	-	-	Represents a typical MIL-STD-1553 bus monitor channel configuration.
MIL-STD-1553 Input	-	-	-
Settings	-	-	-
Maximum Response Time	8 to 31	12	Maximum permitted response time for RT in micro seconds.
Accept Rx Message With No Status	True False	False	Received messages with no status response are stored, when set to True.
Accept Tx Message With No Status	True False	False	Transmitted messages with no status response are stored, when set to True.
Settings Mode Code 17	-	-	Mode Code 17 messages are used to extend the Sub Address range for an RT by providing a Sub-sub Addressing.
Settings Packetizer	-	-	-
Stream Id	00 to FFFFFFFF	FFFFFFF	iNET-X stream ID for selected channel if a packet is generated via the assertion of Packetization Enabled. This setting is only supported in DAS Studio 3.
Packetization Enabled	True False	False	Enables the transmission of an iNET-X packet containing the contents of this channel if an iNET-X transmitter is present in the chassis. This setting is only supported in DAS Studio 3.
Packet Size	200 to 722	722	Size of packet buffer in words.
Packet Timeout	10 to 999	50	Generates a packet when the oldest data recorded is this old (ms).
Processes	-	-	-
Parser(1022:0)	-	-	One of 1023 selective parser slots available per channel.
MIL-STD-1553-In-B(3:0)	-	-	Represents a typical MIL-STD-1553 bus monitor channel configuration.
MIL-STD-1553 Input	-	-	-
Settings Packetizer	-	-	-
Stream Id	00 to FFFFFFFF	FFFFFFF	iNET-X stream ID for selected channel if a packet is generated via the assertion of Packetization Enabled. This setting is only supported in DAS Studio 3.

SETUP DATA	CHOICE	DEFAULT	NOTES
Packetization Enabled	True False	False	Enables the transmission of an iNET-X packet containing the contents of this channel if an iNET-X transmitter is present in the chassis. This setting is only supported in DAS Studio 3.
Packet Size	200 to 722	722	Size of packet buffer in words.
Packet Timeout	10 to 999	50	Generates a packet when the oldest data recorded is this old (ms).

Parameter definitions

NAME/DESCRIPTION	BASE UNIT	DATA FORMAT	BITS	REGISTER DEFINITION
Global Parameters				
Report Reports the status of the module	BitVector	BitVector	16	R[15:0] R(15) ErrorSinceLastRead - 1 indicates error occurred since last read. R[14:13] MIL-STD-1553-In - Indicates which channel the error occurred on. R(12) ErrorOnSecondaryBus - 1 indicates the last error occurred on secondary bus. R[11:6] Reserved - Reserved for future use. R[5:0] ErrorCodes - Indicates the error that occurred last (see "Error codes" in Getting the most from).
BusActive The eight LSBs indicate if a valid message was received on a bus since last read.	BitVector	BitVector	16	R[15:0] R[15:8] Reserved - Reserved for future use. R[15:0] BusActive - A 1 indicates that a valid message was received on a bus in the last second.
Catchall-Parser Parameters				
MessageCount Message counter value when the word was received.	Count	OffsetBinary	16	R[15:0] R[15:0] MessageCount
MessageCommand1 First command word in message.	BitVector	BitVector	16	R[15:0] R[15:0] MessageCommand1
MessageStatus1 First status word stored in message.	BitVector	BitVector	16	R[15:0] R[15:0] MessageStatus1
MessageResponseTime1 First status word's response time in microseconds.	Second	OffsetBinary	16	R[15:0] R[15:0] MessageResponseTime1
MessageData(31:0) MIL-1553 message data	BitVector	BitVector	16	R[15:0] R[15:0] MessageData
MessageCommand2 Second command word of an RT-RT message.	BitVector	BitVector	16	R[15:0] R[15:0] MessageCommand2
MessageStatus2 Second status word of an RT-RT message.	BitVector	BitVector	16	R[15:0] R[15:0] MessageStatus2
MessageResponseTime2 Second status word's response time in microseconds of an RT-RT message.	Second	OffsetBinary	16	R[15:0] R[15:0] MessageResponseTime2

NAME/DESCRIPTION	BASE UNIT	DATA FORMAT	BITS	REGISTER DEFINITION
MessageInfo Stale/skipped indication for this parsed message.	BitVector	BitVector	16	R[15:0] R(15) Empty - 1 indicates this parser slot is empty. R(14) Stale - 1 indicates this message was read before. R(13) Skipped - 1 indicates this message overwrote another. R[12:11] MIL-STD-1553-In - Indicates which channel the message was received on. R(10) MessageOnSecondaryBus - 1 indicates that the message was on the secondary bus. R[9:0] Reserved - Reserved for future use.
MessageIrigTime48 48-bit wide IRIG time word.	BitVector	BitVector	48	R[47:0]
MessageTimeHi Hours and minutes time midway through first transmitted bit.	BitVector	BitVector	16	R[47:32] R[15:13] Reserved - Reserved for future use. R[12:7] Hours - BCD Hours 0 to 23. R[6:0] Minutes - BCD Minutes 0 to 59.
MessageTimeLo Seconds and centiseconds time midway through first transmitted bit.	Second	BCD	16	R[31:16] R(15) Reserved - Reserved for future use. R[14:8] Seconds - BCD Seconds 0 to 59. R[7:0] Centiseconds - BCD Centiseconds 0 to 99.
MessageTimeMicro Microsecond time midway through first transmitted bit.	Second	BCD	16	R[15:0] R[15:0] Microseconds - BCD Microseconds 0 to 9999.
MIL-STD-1553-In-A(3:0) Parameters				
MessageCountA Count of all good messages on the primary bus.	Count	OffsetBinary	16	R[15:0] R[15:0] MessageCountPrimary
ErrorCountA A count of errors detected on the primary bus.	BitVector	BitVector	16	R[15:0] R[15:0] ErrorCount - A count of errors detected on both busses.
WordsPerSecondA The number of MIL-STS-1553 words received on the primary bus in the last second.	BitVector	OffsetBinary	16	R[15:0] R[15:0] WordsPerSecondA
Parser(1022:0) Parameters				
MessageCount Message counter value when the word was received.	Count	OffsetBinary	16	R[15:0] R[15:0] MessageCount
MessageCommand1 First command word in message.	BitVector	BitVector	16	R[15:0] R[15:0] MessageCommand1
MessageStatus1 First status word stored in message.	BitVector	BitVector	16	R[15:0] R[15:0] MessageStatus1
MessageResponseTime1 First status word's response time in microseconds.	Second	OffsetBinary	16	R[15:0] R[15:0] MessageResponseTime1
MessageCommand2 Second command word of an RT-RT message.	BitVector	BitVector	16	R[15:0] R[15:0] MessageCommand2

NAME/DESCRIPTION	BASE UNIT	DATA FORMAT	BITS	REGISTER DEFINITION
MessageStatus2 Second status word of an RT-RT message.	BitVector	BitVector	16	R[15:0] R[15:0] MessageStatus2
MessageResponseTime2 Second status word's response time in microseconds of an RT-RT message.	Second	OffsetBinary	16	R[15:0] R[15:0] MessageResponseTime2
MessageInfo Stale/skipped indication for this parsed message.	BitVector	BitVector	16	R[15:0] R(15) Empty - 1 indicates this parser slot is empty. R(14) Stale - 1 indicates this message was read before. R(13) Skipped - 1 indicates this message overwrote another. R[12:11] MIL-STD-1553-In - Indicates which channel the message was received on. R(10) MessageOnSecondaryBus - 1 indicates that the message was on the secondary bus. R[9:0] Reserved - Reserved for future use.
MessageIrigTime48 48-bit wide IRIG time word.	BitVector	BitVector	48	R[47:0]
MessageTimeHi Hours and minutes time midway through first transmitted bit.	BitVector	BitVector	16	R[47:32] R[15:13] Reserved - Reserved for future use. R[12:7] Hours - BCD Hours 0 to 23. R[6:0] Minutes - BCD Minutes 0 to 59.
MessageTimeLo Seconds and centiseconds time midway through first transmitted bit.	Second	BCD	16	R[31:16] R(15) Reserved - Reserved for future use. R[14:8] Seconds - BCD Seconds 0 to 59. R[7:0] Centiseconds - BCD Centiseconds 0 to 99.
MessageTimeMicro Microsecond time midway through first transmitted bit.	Second	BCD	16	R[15:0] R[15:0] Microseconds - BCD Microseconds 0 to 9999.
MIL-STD-1553-In-B(3:0) Parameters				
MessageCountB Count of all good messages on the secondary bus.	Count	OffsetBinary	16	R[15:0] R[15:0] MessageCountSecondary
ErrorCountB A count of errors detected on the secondary bus.	BitVector	BitVector	16	R[15:0] R[15:0] ErrorCount - A count of errors detected on both busses.
WordsPerSecondB The number of MIL-STS-1553 words received on the secondary bus in the last second.	BitVector	OffsetBinary	16	R[15:0] R[15:0] WordsPerSecondB

NOTE: It is recommended that names are less than 20 characters, have no white space or contain any of the following five characters "/><\".

Getting the most from the KAD/MBM/102

For a detailed description on iNET-X packets, see *TEC/NOT/067 - IENA and iNET-X packet payload formats*.

iNET-X parser-aligned packet format

There is a diverse range of avionic bus technologies for which traffic may be captured, for example, MIL-STD-1553, PCM, or ARINC-429. The generalized iNET-X payload structure for parser-aligned packets is shown in the following figure.

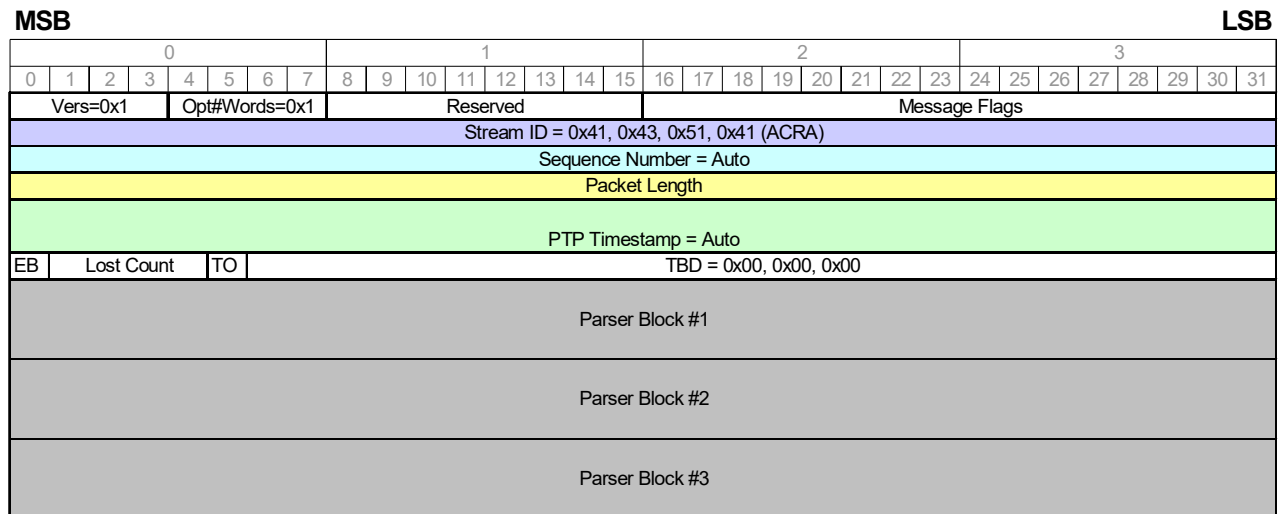

Figure 2: Generalized parser-aligned iNET-X packet

As messages are captured on the bus, they are formatted in a parser block. Each parser block begins with a 4-byte parser information word, followed by a 4-byte elapsed time tag and the message data shown in the following figure.

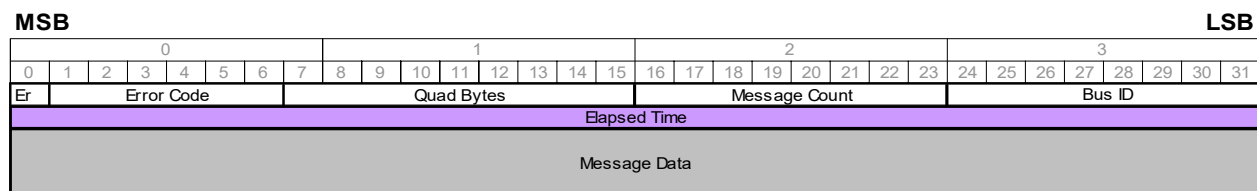

Figure 3: iNET-X parser block

A parser block consists of the following fields:

- Parser information word (4 bytes): metadata providing information about the health and status of the message.
 - + Er (Bit 0): indicates that an error occurred.
 - + Bits [1:6]: Reserved.
 - + Quad bytes (Bits [7:15]): number of quad bytes. This relates to the length of the parser information word, elapsed time tag, and the message data and padding (N x 4 bytes). For example, a 4-byte message captured from a given bus has a quad-byte value of 3, that is 12 bytes that includes 4 bytes parser information word, 4 bytes elapsed time, and 4 bytes bus message data.
 - + Message count (Bits [16:23]): message counter. This is a message counter that relates to the messages contained in the payload. The message counter increments for each message contained in the packet payload and continues to increment across consecutive packets. The message counter resets and wraps around to 0 once it has reached the maximum message count of 0xFF.
 - + Bus ID (Bits [24:31]): bus number.
- Elapsed time (4 bytes): time tag as an unsigned offset in nanoseconds that is added to the base PTP timestamp in the iNET-X

header.

- Message data (N x 4 bytes): captured bus traffic, padded if necessary to end on 4-byte boundary.

iNET-X parser-aligned packet structure for MIL-STD-1553 bus monitoring

As MIL-STD-1553 messages arrive, the MIL-STD-1553 protocol tracker logic identifies them and maps them to corresponding transaction identifier codes, as in the following table.

TABLE 3		Transaction identifier codes	
MESSAGE TYPE	MNEMONIC	TRANSACTION ID	
Bus Controller to Remote Terminal	BC -> RT	0x00	
Remote Terminal to Bus Controller	RT -> BC	0x01	
Remote Terminal to Remote Terminal	RT -> RT	0x02	
Mode Code without Data	M -> S	0x03	
Mode Code with Data (R)	MD -> S	0x04	
Mode Code with Data (T)	M -> SD	0x05	
BROADCAST			
Bus Controller to Remote Terminals	BC -> RTS	0x06	
Remote Terminal to Remote Terminals	RT -> RTS	0x07	
Mode Code without Data	M	0x08	
Mode Code with Data (R)	MD	0x09	
MESSAGES WITHOUT STATUS REPLY			
Bus Controller to Remote Terminal	BC -> RT	0x10	
Remote Terminal to Bus Controller	RT -> BC	0x11	
Remote Terminal to Remote Terminal	RT -> RT	0x12	
Mode Code without Data	M -> S	0x13	
Mode Code with Data (R)	MD -> S	0x14	
Mode Code with Data (T)	M -> SD	0x15	
Remote Terminal to Remote Terminal	RT -> RTS	0x17	

Only valid MIL-STD-1553 transactions are stored in the packet (see the following figure). If an error occurs, only the parser information word and elapsed time tag are written to the iNET-X packet; the message is then dumped. The error bit and error code (see the previous table), which are set in the parser information word, indicate the cause of the error.

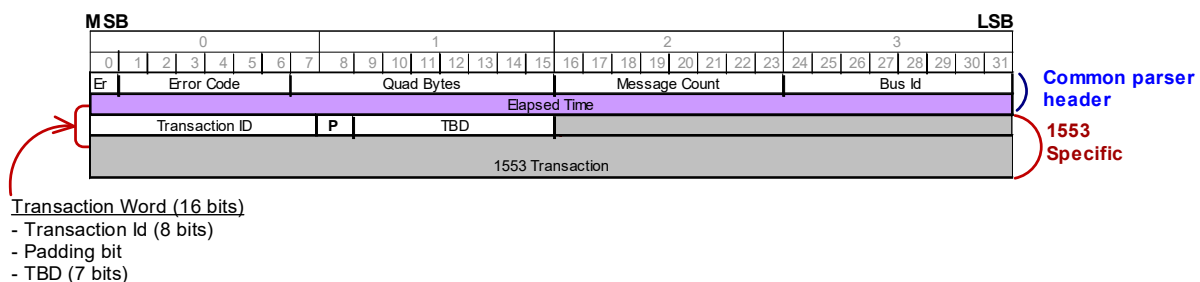

Figure 4: MIL-STD-1553 transaction iNET-X parser-aligned packet

In the case where a remote terminal is off-line but it is still desirable to capture data sent to it, you can set options to include Accept Rx Message With No Status and Accept Tx Message With No Status. In such a scenario, the parser information word indicates an error but the 1553 traffic is still captured.

The transaction identifier may be used to indicate when response times are carried in the iNET-X parser-aligned block. The MIL-STD-1553 standard specifies a minimum response time of 4µs and a maximum response time of 12µs. However, the bus controller waits up to 20µs before determining a timeout has occurred. The granularity of response time on the 8MHz bus can be measured to a resolution of 125ns. When a timeout occurs, the response time is set to 0xFF.

In order to facilitate the decoding and decommutation of the MIL-STD-1553 parser-aligned iNET-X packets, the first word of a MIL-STD-1553 transaction is the transaction word where:

- Transaction word (2 bytes): metadata providing protocol tracking information, health, and status of the message.
 - + Transaction ID (Bits [0:7]): see Table 3 on page 8
 - + P (Bit 8): bit to indicate if the parser message has been padded to fall on a 4-byte boundary
 - + TBD (Bits [9:15]): TBD

Where a MIL-STD-1553 transaction does not fall on a 32-bit boundary, the MIL-STD-1553 parser-aligned message is padded. In MIL-STD-1553 the maximum number of padding words (16-bit) possible in a single transaction is one. Therefore a single bit is sufficient to indicate if a transaction message has been padded. Figure 5 on page 9 and Figure 6 on page 9 illustrate individual MIL-STD-1553 BC -> RT transactions, with and without padding.

MSB																LSB																	
0								1								2								3									
0	1	2	3	4	5	6	7	8	9	10	11	12	13	14	15	16	17	18	19	20	21	22	23	24	25	26	27	28	29	30	31		
Er		Error Code						Quad Bytes=6						Message Count						Bus ID													
Elapsed Time																																	
Transaction ID: RT->BC								P=0		TBD								Cmd=TX															
Response																Status																	
Data#1																Data#2																	
Data#3																Data#4																	

Figure 5: MIL-STD-1553 transaction iNET-X parser-aligned message without padding

MSB																LSB																	
0								1								2								3									
0	1	2	3	4	5	6	7	8	9	10	11	12	13	14	15	16	17	18	19	20	21	22	23	24	25	26	27	28	29	30	31		
Er		Error Code						Quad Bytes=7						Message Count						Bus ID													
Elapsed Time																																	
Transaction ID: BC->RT								P=1		TBD								Cmd=RX															
Data#1																Data#2																	
Data#3																Data#4																	
Data#5																Response																	
Status																Padding																	

Figure 6: MIL-STD-1553 transaction iNET-X parser-aligned message with padding

Figure 7 on page 10 demonstrates the iNET-X parser-aligned payload structure for MIL-STD-1553 with the following three parsed MIL-STD-1553 transactions in the payload:

- BC -> RT: With four data words transferred.
- RT -> RT: With five data words transferred.
- RT -> BC: With four data words transferred.

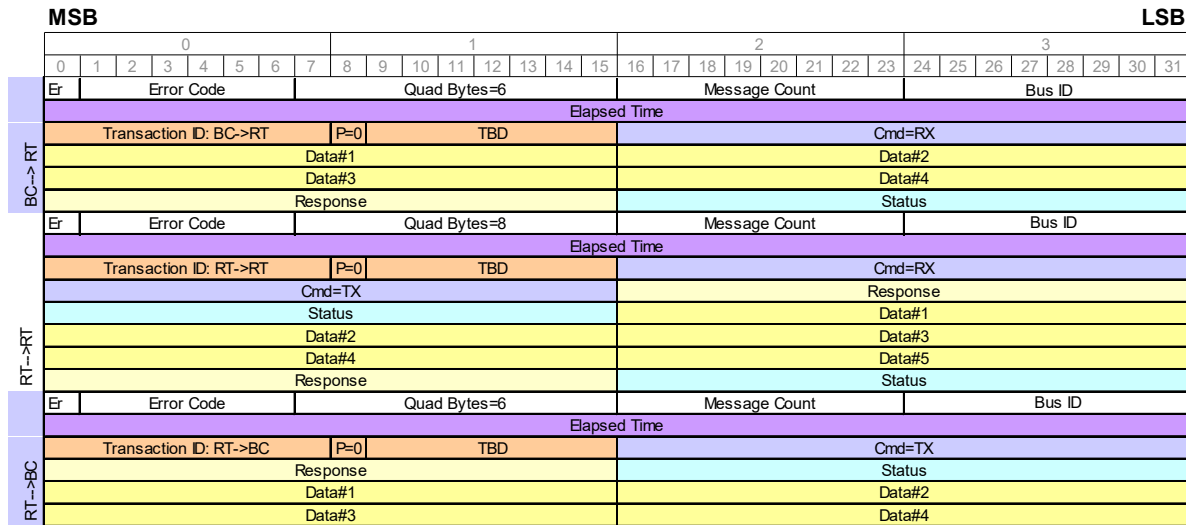

Figure 7: iNET-X parser-aligned payload for multiple MIL-STD-1553 transactions

For example, the MIL-STD-1553 bus has a peak bit-rate of 1Mbps. However, the messages and transactions transmitted are variable in length and asynchronous. If it is assumed that the mean MIL-STD-1553 transaction is 14 bytes long (comprising of a command, response, data words, and a status word), the iNET-X parser block structure encapsulating this transaction is therefore 24 bytes (including the MIL-STD-1553 transaction ID, parser information word and the elapsed time). In this case, each iNET-X parser-aligned packet may contain up to 60 parser blocks in the payload (that is, 60 parser blocks x 24 bytes per block which results in 1440 bytes of payload, or 840 bytes of MIL-STD-1553 bus data). To ensure that no data is lost on the bus, packets are generated at a rate of 150 packets per second.

The transmission properties for a 1Mbps MIL-STD-1553 bus are summarized in the following table.

TABLE 4	MyMIL-STD-1553 packet transmission properties
TRANSMISSION PROPERTY	VALUE
MIL-STD-1553 packet payload size (bytes)	1440 bytes (60 MIL-STD-1553 parser blocks of 24 bytes per block where each block contains 14 bytes of MIL-STD-1553 bus data)
Total Ethernet frame length (bytes)	1514 bytes (MAC header 14 bytes + IP 20 bytes + UDP 8 bytes + iNET-X 28 bytes + MIL-STD-1553 data + MAC FCS 4 bytes)
Packet rate (packets per second)	150
Total number of MIL-STD-1553 transactions per packet	60 transactions assuming 14 bytes per transaction
Total bit-rate (kbps)	1816.8

TABLE 5	Error codes			
ERROR CODE	DESCRIPTION	ERROR CODE	DESCRIPTION	
0 ₁₆	Reserved for future use.	20 ₁₆	Expected STS was a data word.	
1 ₁₆	Data word did not have enough bits.	21 ₁₆	Expected STS was invalid.	
2 ₁₆	Data word had bit error.	22 ₁₆	Expected STS had incorrect RT.	
3 ₁₆	Data word had parity error.	23 ₁₆	Expected STS had contiguous traffic.	
4 ₁₆	Non-data word did not have enough bits.	24 ₁₆	Expected STS timed out.	
5 ₁₆	Non-data word had bit error.	25 ₁₆	Expected STS had no contiguous data word.	
6 ₁₆	Non-data word had parity error.	26 ₁₆	Reserved for future use.	

TABLE 5		Error codes (continued)	
ERROR CODE	DESCRIPTION	ERROR CODE	DESCRIPTION
7 ₁₆	Reserved for future use.	27 ₁₆	Reserved for future use.
8 ₁₆	Expected data word was non-data word.	28 ₁₆	Reserved for future use.
9 ₁₆	Expected data word did not have contiguous word.	29 ₁₆	Reserved for future use.
A ₁₆	Expected last data word was not last.	2A ₁₆	Reserved for future use.
B ₁₆	Expected mode data word was non-data word.	2B ₁₆	Expected Tx CMD of RT to RT(s) had different number of words than Rx CMD.
C ₁₆	Expected mode data word has contiguous traffic.	2C ₁₆	Expected Tx CMD of RT to RT(s) had same RT as Rx CMD.
D ₁₆	Reserved for future use.	2D ₁₆	Expected Tx CMD of RT to RT(s) had contiguous traffic.
E ₁₆	Reserved for future use.	2E ₁₆	Second CMD in RT-RT was not a TX.
F ₁₆	Reserved for future use.	2F ₁₆	Reserved for future use.
10 ₁₆	Expected first CMD was a data word.	30 ₁₆	Reserved for future use.
11 ₁₆	Reserved for future use.	31 ₁₆	Reserved for future use.
12 ₁₆	Reserved for future use.	32 ₁₆	Reserved for future use.
13 ₁₆	Reserved for future use.	33 ₁₆	Reserved for future use.
14 ₁₆	Reserved for future use.	34 ₁₆	Reserved for future use.
15 ₁₆	Expected first CMD had contiguous traffic.	35 ₁₆	Reserved for future use.
16 ₁₆	Expected first CMD was Rx with no contiguous data word.	36 ₁₆	Reserved for future use.
17 ₁₆	Expected first CMD was Mode with no contiguous data.	37 ₁₆	Reserved for future use.
18 ₁₆	Expected second STS of RT to RT was data word.	38 ₁₆	Reserved for future use.
19 ₁₆	Expected second STS of RT to RT had incorrect RT.	39 ₁₆	Reserved for future use.
1A ₁₆	Expected second STS of RT to RT had contiguous traffic.	3A ₁₆	Reserved for future use.
1B ₁₆	Expected second STS of RT to RT timed out.	3B ₁₆	Reserved for future use.
1C ₁₆	Reserved for future use.	3C ₁₆	Reserved for future use.
1D ₁₆	Reserved for future use.	3D ₁₆	Reserved for future use.
1E ₁₆	Reserved for future use.	3E ₁₆	Reserved for future use.
1F ₁₆	Reserved for future use.	3F ₁₆	Reset occurred since last read.

Tx = transmit; STS = status; CMD = command.

Detecting messages when a remote terminal is off-line

When a MIL-STD-1553 remote terminal is off-line, it does not respond (with a status word) to bus controller Rx commands or it does not respond (with a status word followed by data) to bus controller Tx commands.

To acquire data from MIL-STD-1553 messages, which have been sent from the bus controller to off-line remote terminals, see “Message capture settings” on page 12. To determine, via telemetry, if a remote terminal is off-line, see “Detecting when a Tx remote terminal is off-line” on page 12.

Message capture settings

The following settings can be used to capture messages when the remote terminal is off-line:

- AcceptRxMessageWithNoStatus
- AcceptTxMessageWithNoStatus

NOTE: The message counter on the KAD/MBM/102 counts all messages that go into the parser (two dedicated counters for bus primary/secondary), which are defined by either AcceptRxMessageWithNoStatus or AcceptTxMessageWithNoStatus.

AcceptRxMessageWithNoStatus

If any remote terminals monitoring the MIL-STD-1553 bus are likely to be off-line, set AcceptRxMessageWithNoStatus to Yes. When AcceptRxMessageWithNoStatus is set to Yes, the KAD/MBM/102 captures data from Rx command messages, where the remote terminal does not respond with a status word. In this scenario, the status word in the parser is hex FFFF.

If AcceptRxMessageWithNoStatus is set to No, then only complete messages, where a remote terminal responds, are captured.

AcceptTxMessageWithNoStatus

When AcceptTxMessageWithNoStatus is set to Yes, the KAD/MBM/102 accepts Tx command messages where the remote terminal does not respond. In this scenario, only the Tx command appears on the MIL-STD-1553 bus, the KAD/MBM/102 parser data is invalid, the status word in the parser is hex FFFF, and time stamps record any occurrence of the command word.

The AcceptTxMessageWithNoStatus setting enables the capture of messages when the remote terminal is off-line. However, for this setting to have an effect, AcceptRxMessageWithNoStatus must be set to Yes.

When AcceptTxMessageWithNoStatus is set to No, the

KAD/MBM/102 rejects Tx command messages where the remote terminal does not respond. The effect on the parser is that the last valid message with the last valid data and time stamps remain.

Detecting when a Tx remote terminal is off-line

To detect when a Tx remote terminal is off-line, set AcceptTxMessageWithNoStatus to Yes. The parser status word must be sent to detect this and then be processed in the ground station. If the status word is hex FFFF, the ground station must deal with the invalid data in the parser. Otherwise, the data shows spikes.

Response time

One feature of the KAD/MBM/102 is the ability to program the response timeout. This value should reflect the actual response timeout on the MIL-STD-1553 bus. Under normal circumstances, a remote terminal responds within 4 to 12ms. However a remote terminal should wait a minimum of 14ms before considering that the remote terminal has timed out. Some implementations of MIL-STD-1553 have deviated from the standard and have their own response times. For this reason, the expected response time is configurable on the KAD/MBM/102.

It is important that the KAD/MBM/102 has response time configured correctly because there may be confusion over which MIL-STD-1553 messages certain control words belong to. In MIL-STD-1553, the command word and status word have the same signature. For example, if the response time is set too high, and if there is no response from a particular RT, the next command word may belong to that message as a status word. This may cause issues parsing the next message. If the response time is set too low, then the KAD/MBM/102 may consider that a valid message has timed out due to no response. The status of this message appears as the next command. This may cause issues parsing the next message and so on.

Parser sample rate

The KAD/MBM/102 parser is triple buffered. If there is a burst of more than three messages between parser sampling intervals, the triple buffer can be saturated. Therefore, if it is necessary that all messages get captured, the parser data must be sampled at the speed of the burst if this is above the aggregate rate.

Variable sized messages

By default, the KAD/MBM/102 is configured to parse any number of data words for a particular message. It is also possible to parse messages of particular sizes.

In cases where there are variable sized messages and when

word count is set to All, care must be taken when processing the data. The parser only updates the data words that appear on the MIL-STD-1553 bus. The other words are not valid. This means that the ground station or post processing must use the number of data words indicated in the command word to identify which data words are valid. The other option is to parse particular message sizes individually.

Connector pinout of the KAD/MBM/102

PIN	NAME	SEE SPECIFICATIONS TABLE	COMMENT
1	DATA_DC_A(0)+	MIL-STD-1553	Direct coupled primary input of bus(0)
2	DATA_TC_A(0)+	MIL-STD-1553	Transformer coupled primary input of bus(0)
3	DATA_DC_B(0)+	MIL-STD-1553	Direct coupled secondary input of bus(0)
4	DATA_TC_B(0)+	MIL-STD-1553	Transformer coupled secondary input of bus(0)
5	DATA_DC_A(1)+	MIL-STD-1553	Direct coupled primary input of bus(1)
6	DATA_TC_A(1)+	MIL-STD-1553	Transformer coupled primary input of bus(1)
7	DATA_DC_B(1)+	MIL-STD-1553	Direct coupled secondary input of bus(1)
8	DATA_TC_B(1)+	MIL-STD-1553	Transformer coupled secondary input of bus(1)
9	DATA_DC_A(2)+	MIL-STD-1553	Direct coupled primary input of bus(2)
10	DATA_TC_A(2)+	MIL-STD-1553	Transformer coupled primary input of bus(2)
11	DATA_DC_B(2)+	MIL-STD-1553	Direct coupled secondary input of bus(2)
12	DATA_TC_B(2)+	MIL-STD-1553	Transformer coupled secondary input of bus(2)
13	DATA_DC_A(3)+	MIL-STD-1553	Direct coupled primary input of bus(3)
14	DATA_TC_A(3)+	MIL-STD-1553	Transformer coupled primary input of bus(3)
15	DATA_DC_B(3)+	MIL-STD-1553	Direct coupled secondary input of bus(3)
16	DATA_TC_B(3)+	MIL-STD-1553	Transformer coupled secondary input of bus(3)
17	DNC		Do not connect
18	DNC		Do not connect
19	DATA_DC_A(0)-	MIL-STD-1553	Direct coupled primary input of bus(0)
20	DATA_TC_A(0)-	MIL-STD-1553	Transformer coupled primary input of bus(0)
21	DATA_DC_B(0)-	MIL-STD-1553	Direct coupled secondary input of bus(0)
22	DATA_TC_B(0)-	MIL-STD-1553	Transformer coupled secondary input of bus(0)
23	DATA_DC_A(1)-	MIL-STD-1553	Direct coupled primary input of bus(1)
24	DATA_TC_A(1)-	MIL-STD-1553	Transformer coupled primary input of bus(1)
25	DATA_DC_B(1)-	MIL-STD-1553	Direct coupled secondary input of bus(1)
26	DATA_TC_B(1)-	MIL-STD-1553	Transformer coupled secondary input of bus(1)
27	DATA_DC_A(2)-	MIL-STD-1553	Direct coupled primary input of bus(2)
28	DATA_TC_A(2)-	MIL-STD-1553	Transformer coupled primary input of bus(2)
29	DATA_DC_B(2)-	MIL-STD-1553	Direct coupled secondary input of bus(2)
30	DATA_TC_B(2)-	MIL-STD-1553	Transformer coupled secondary input of bus(2)
31	DATA_DC_A(3)-	MIL-STD-1553	Direct coupled primary input of bus(3)
32	DATA_TC_A(3)-	MIL-STD-1553	Transformer coupled primary input of bus(3)
33	DATA_DC_B(3)-	MIL-STD-1553	Direct coupled secondary input of bus(3)
34	DATA_TC_B(3)-	MIL-STD-1553	Transformer coupled secondary input of bus(3)
35	DNC		Do not connect
36	CHASSIS	Chassis	
37	GND	Internal ground	
38	CHASSIS	Chassis	
39	GND	Internal ground	
40	CHASSIS	Chassis	
41	GND	Internal ground	
42	CHASSIS	Chassis	
43	GND	Internal ground	
44	CHASSIS	Chassis	
45	GND	Internal ground	
46	CHASSIS	Chassis	
47	GND	Internal ground	
48	CHASSIS	Chassis	
49	GND	Internal ground	
50	CHASSIS	Chassis	
51	GND	Internal ground	
52	CHASSIS	Chassis	

Ordering information

PART NUMBER	DESCRIPTION
KAD/MBM/102	MIL-STD-1553 bus monitor parser/packetizer - 4ch dual redundant (transformer coupled/direct coupled)

When ordering, specify which connector (ASD/MBM/102/TCC for transformer coupled; or ASD/MBM/102/DCC for direct coupled) is preferred. Its part number will be added to the Confirmation of Order unless an alternative option is specified (see the *Cables* data sheet).

Revision history

REVISION	DIFFERENCES	STATUS
KAD/MBM/102	First release	Recommended for new programs

Supporting software

SOFTWARE	DETAILS
DAS Studio 3	User interface for setup and management of data acquisition, network switches, recorders and ground stations in an integrated environment

Related products

MODULE	DETAILS
ASD/MBM/102/TCC	MIL-STD-1553 transformer coupled interface cable (45cm) with eight Twinax TRB connectors (shield connected to chassis)
ASD/MBM/102/DCC	MIL-STD-1553 direct coupled interface cable (45cm) with eight Twinax TRB connectors (shield connected to chassis)

Related documentation

DOCUMENT	DETAILS
DOC/DBK/001	Acra KAM-500 Databook
DOC/GBK/002	Environmental Qualification Handbook
DOC/MAN/030	DAS Studio User Manual
TEC/NOT/004	MIL-STD-1553
TEC/NOT/016	Power dissipation
TEC/NOT/049	Power estimation
TEC/NOT/051	Ethernet frames, Wireshark® and FAT32
TEC/NOT/067	IENA and iNET-X packet payload formats

This page is intentionally blank